

PALANDA- MAX

1020x1600x2050

č. 258/BC

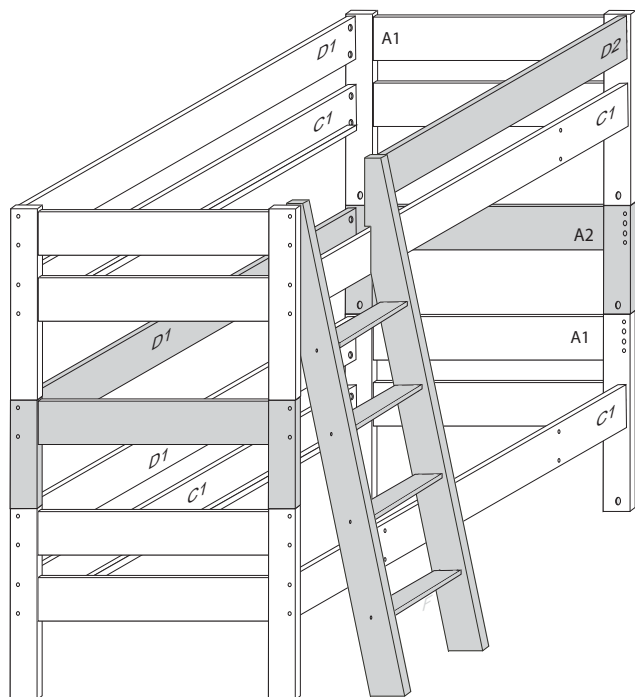

	1 x1	4 x1	5 x1	9 x24	12 x6	12a x8
		č.4	č.5	10x50mm	6x80mm	
37 x4	38 x2		43a x4	43b x2	45 x8	47 x8
5x30mm	5x60mm		6x60mm	6x12mm	8x125mm	13.601
72 x10		87 x8	88 x8	89 x4	90 x8	109 x2
7x70mm		7mm	10mm	25mm		110 x2
						10x50mm

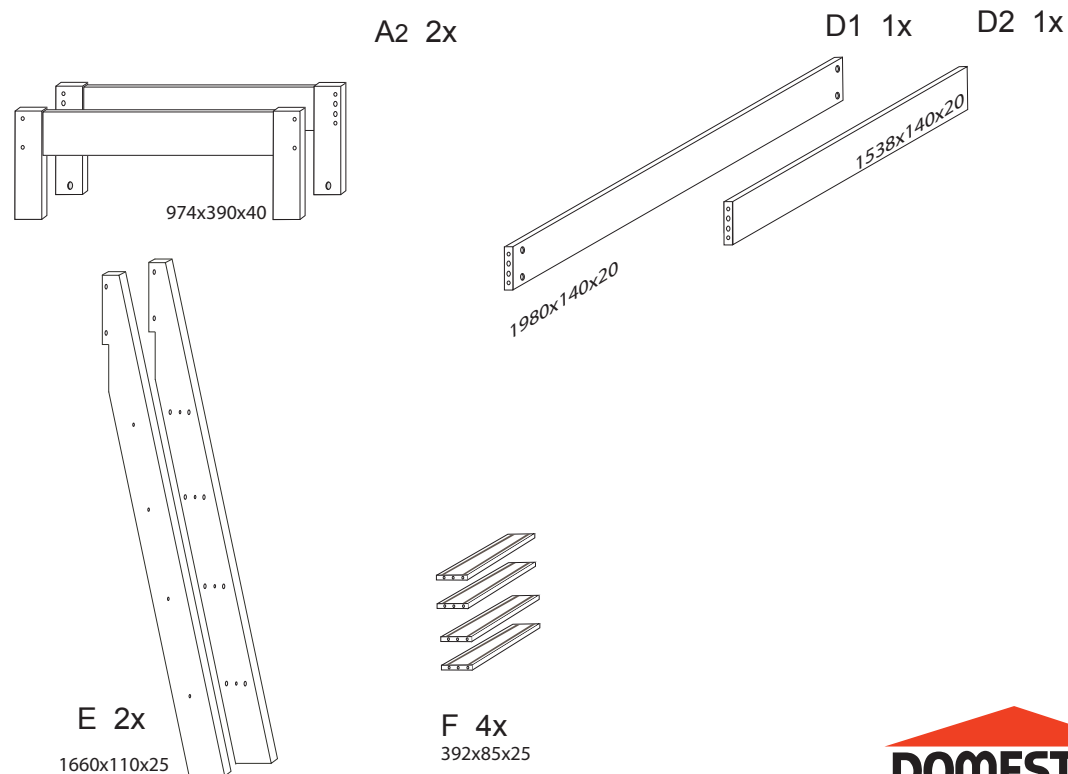

Kolíky vždy narazte nejprve do otvorů ve hranách dílců, je nutné je zarazit se stejným přesahem. V případě, že některý kolík přesahuje, je nutné jej zakrátit. Dílce srážejte kladivem pouze přes dřevěnou podložku.

V případě vrzání vtačte do spoje tekuté mýdlo v poměru 1:1 s vodou. Tento jev se u nábytku z masivu vyskytuje běžně.

1

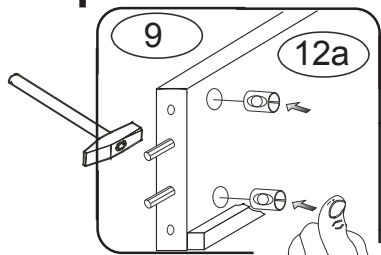

Kolíky nesmí z bočnic vyčnívat více než 17mm.

2

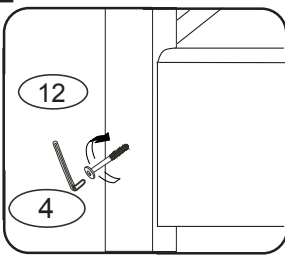

Pokud jdou šrouby obtížně dotáhnout, tak NEDOTAHUJTE, nejprve zakračte kolíky v bočnicích

3

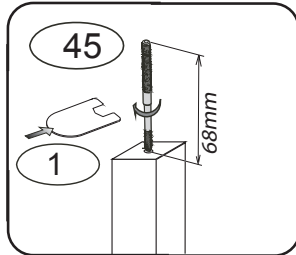

pro snazší zašroubování namažte šroub mýdlem nebo olejem

4

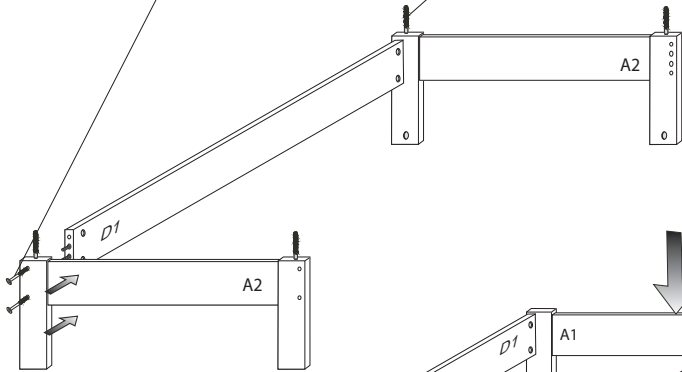
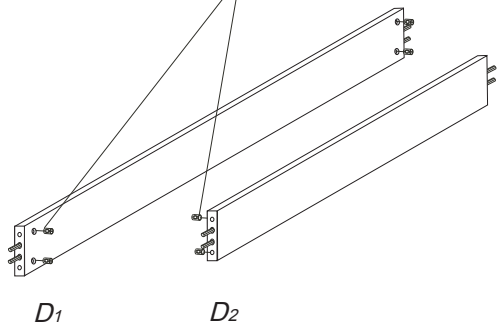
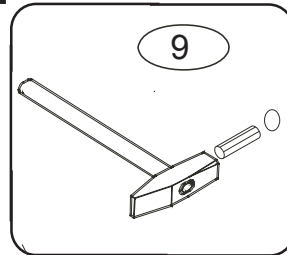

6

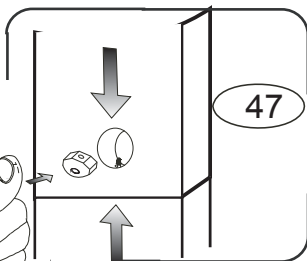

7

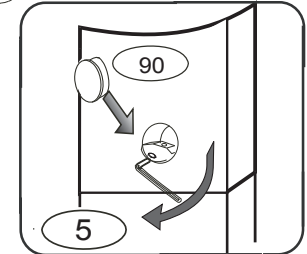

8

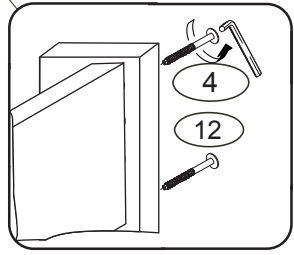

5

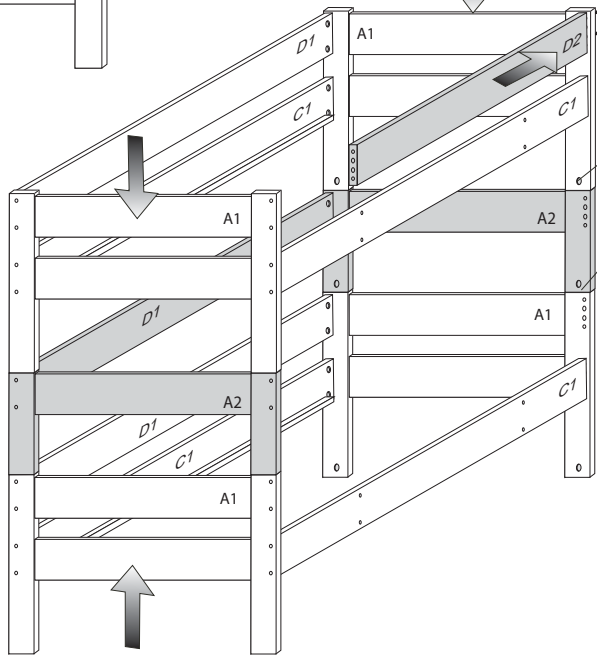
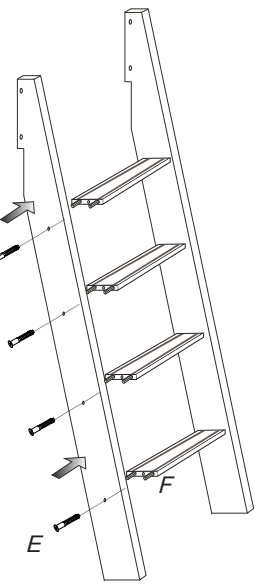
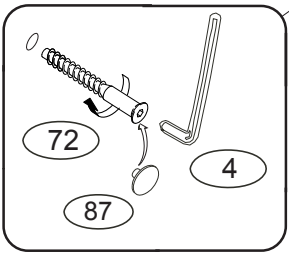

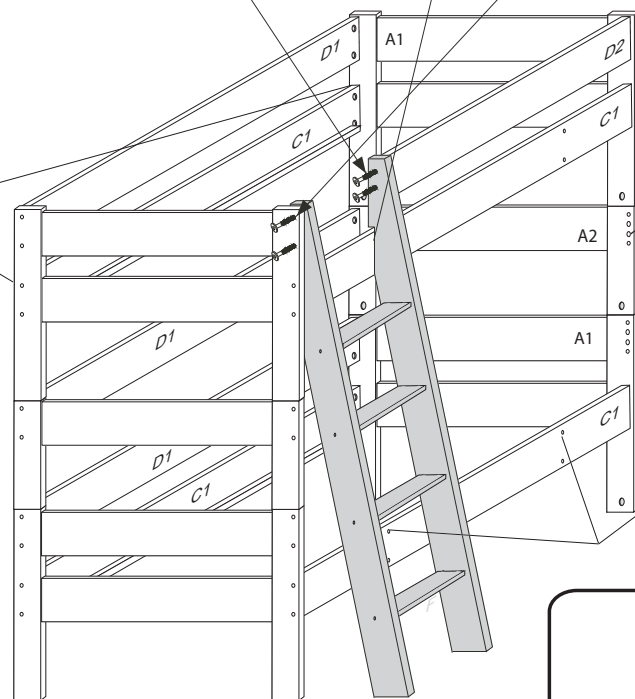
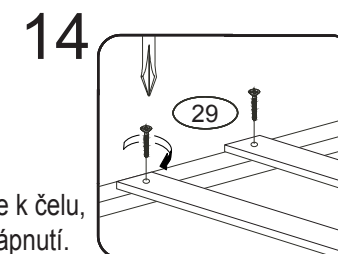
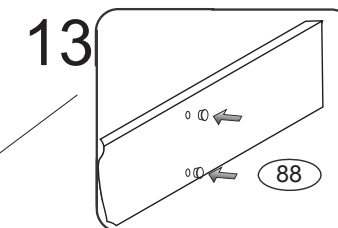
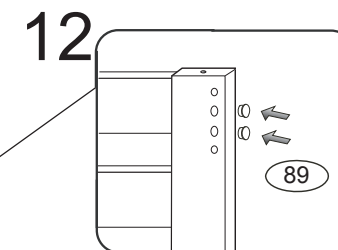
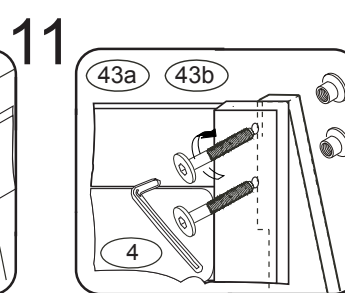
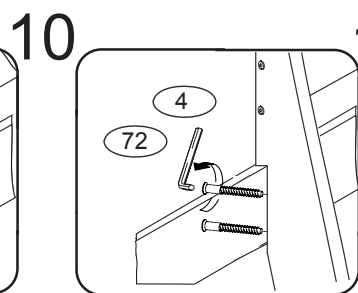
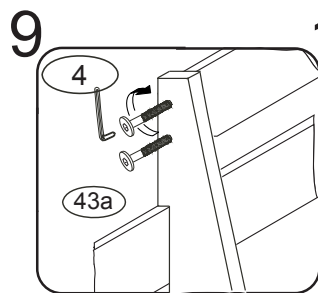
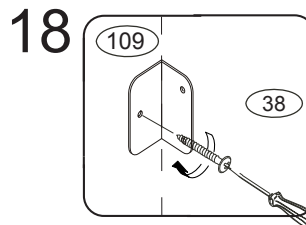
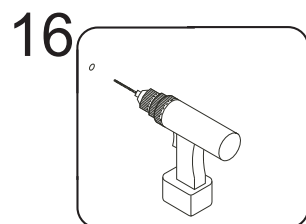
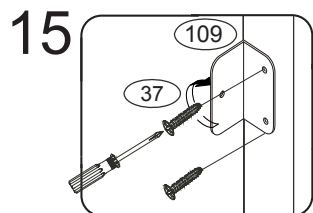

Přišroubujte rošty.
Poslední laťku roštu
přišroubujte co nejdříve k čelu,
aby se zabránilo prošlápnutí.

POKyny!

- Uvědomte si nebezpečí pádu malých dětí (do 6 let) z horní postele.
- Horní plocha matrace. nesmí přesáhnout červenou rysku na stojně zábrany.
- Maximální výška matrace pro horní lůžko je 210mm.
- Bezpečnostní požadavky dle normy ČSN EN 747-1